



ACO Access

Rhinocast Installation Manual

Preparation
Inspection
Installation
Maintenance



Rhinocast® - Ductile Iron Access Covers

GETTING STARTED

ACO is Australia's foremost supplier of cover and frame systems for buildings, urban and civil infrastructure projects. ACO manufactures a range of high quality AS 3996 compliant access covers. The range comprises Rhinocast Infill and Solid Top covers in single part, 2-part, trench run and multipart configurations.

ACO's Rhinocast covers must be properly installed to prevent unwanted movement, damage, and failure when covers are under load.

Typical installation equipment needed may include:

- Rhinocast lifting keys
- Shifting spanner
- Measuring tools
- Markers
- Packing materials
- Leveling equipment
- Sealing grease
- Concrete
- Rubber mallet
- Personal protective equipment (PPE), as required



Contents

1. Rhinocast® - Ductile Iron Access Covers	2
2. Key Installation Requirements	3
3. Installation Procedure for Single Part, 2-Part Covers and Trench Runs	6
4. Installation Procedure for Multipart Cover Systems	11
5. Maintenance and Access Procedure	17

2

Key Installation Requirements

CLEAR OPENING

The clear opening is the unobstructed opening inside the frame, see **Figure 1**. The clear opening of the frame must be equal to or larger than the clear opening of the pit.

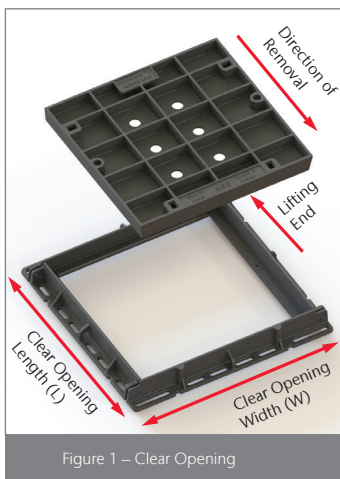

Figure 1 – Clear Opening

REBATE DIMENSIONS

To support the anticipated loads, cast the rebate according to **Figure 2**. For covers with decorative edging add the height of the edging to the recommended rebate depths. The rebate dimensions are based on the assumption that the concrete slab is designed for the anticipated loads. Alternatively for other pavement types, a concrete collar is cast around the cover and frame, details at:

www.acoaccess.com.au/product-support/installation-guidance/#rhinocast

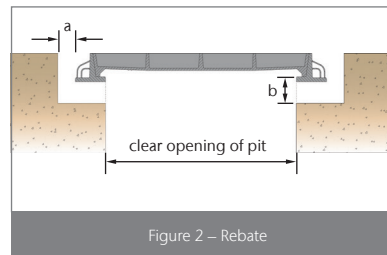

Figure 2 – Rebate

DIMENSIONS

Dimensions are given as width (W) by length (L), refer to ACO Access brochure and Specification Information sheets, details at:

www.acoaccess.com.au/product-support/downloads

Ductile iron covers are specified with the width parallel to the lifting end. Length is parallel to the direction of cover removal.

Load Class	a	b
B	30	30
C/D	50	50
G	50	75

Table 1 – Rebate Dimensions

LOAD CLASS

Select the correct Rhinocast® ductile iron access cover for the required load class and application. Refer to pages 4-9 in the ACO Access brochure, download at:

www.acoaccess.com.au/product-support/downloads

COVERS & FRAMES

Covers and frames are always paired together and should not be mixed, as this may compromise the seal and fitment.

PACKING MATERIAL

Use non-compressive packing material such as plastic packers, steel spacers, fibre cement, etc. Avoid using wood as it is compressible and would cause destabilisation. In the long term, rotting wood will produce unacceptable voids in the concrete.

RHINOCAST® LIFTING KEYS

It is important that the appropriate Rhinocast® lifting keys are used, see **Figure 3 and 4**. To remove a Rhinocast cover, insert the key and rotate clockwise a quarter turn and lock the nut into position. Position the jacking bolt over the frame and screw down using a shifting spanner to break the seal.

For added protection against damage to tile, paver, or concrete infill, use at least 100 x 100 x 3mm thick steel plate under the jacking bolt for decorative edge covers.



Figure 3 – Short Handle Lifter (pair) Part No. 84654

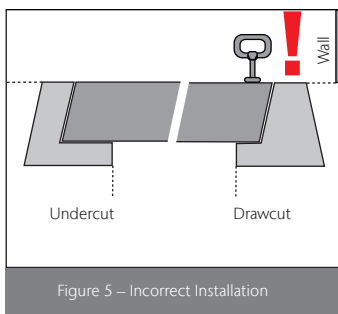

Figure 4 – Long Handle Lifter (pair) Part No. 84854

COVER ORIENTATION

The lifting keyholes are located at the drawcut edge of the cover.

The lifting holes should never be positioned near a barrier or wall as it prevents cover removal, see **Figure 5**. Cover and frames to be rotated 90 or 180 degrees for ease of removal.



INSTALLATION GUIDANCE

Additional information can be found at:

www.acoaccess.com.au/product-support/installation-guidance/

DECORATIVE EDGING

A strip of stainless steel or brass can be added to the cover and frame's edge to accommodate tiles or pavers. 12mm high edge recommended for tiles and a 40mm high edge recommended for pavers. See **Figure 6**.

For these applications, keyhole bosses will also have extensions to match the height and material finish of the decorative edge. The top of the decorative edge corresponds with the finished floor level of the cover. Ensure that the rebate has been formed with an allowance for the relevant height extensions. Refer to **Figure 2** for standard rebate dimensions.

Tiles or pavers should be fully restrained and bonded to the concrete bed. An epoxy mortar is recommended.

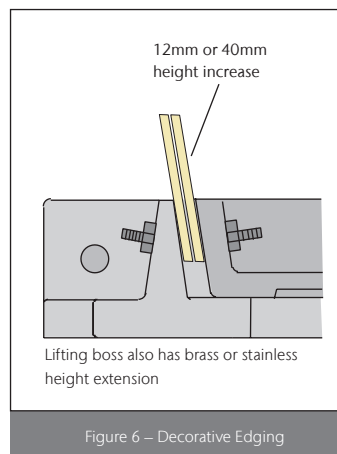

3

Installation Procedure For Single Part, 2-Part Covers and Trench Runs

Step 1. Form the pit and rebate.

Size the access pit and rebate to match the load class requirements. The clear opening of the frame must be equal to or larger than the clear opening of the pit. See Figure 7.

Refer to Figure 2 for recommended rebate dimensions in a concrete slab/pit.

Alternatively, for other pavement types, a concrete collar is cast around the cover and frame, details at:

www.acoaccess.com.au/product-support/installation-guidance/#rhinocast

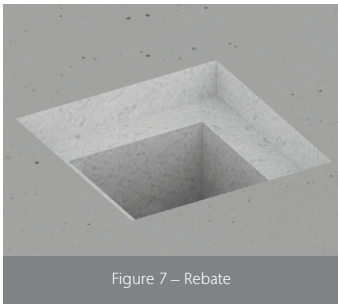

Figure 7 – Rebate

Step 2. Remove cover from frame.

Take off all the caps and locking bolts. Remove the covers from the frame. Use one of the Rhinocast lifting keys, choosing the appropriate one. See Figures 3 and 4 for the options. Lift at the drawcut edge that has two lifting keyholes.

For 2-part covers, and trench runs, mark the frame and covers at the lifting end to ensure reinstallation in the same position.

Match the frame marks with the lifting key holes to lift safely.

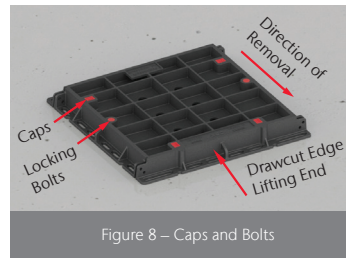

Figure 8 – Caps and Bolts

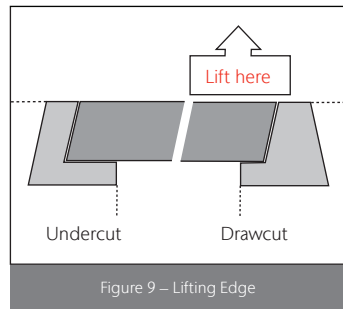

Figure 9 – Lifting Edge

Step 3. Position frame in rebate.

Place the frame on the rebate and ensure it does not protrude into the pit opening. Caution, check that the lifting end is not obstructed to avoid issues during cover removal, see Figure 5.

Pack under the corner of the frame joints to raise and level the top of frame (or decorative edge) to the finished floor level.

Ensure the packing does not protrude into the pit opening.

For 2-part covers and trench runs, pack under the additional frame joints to prevent the frame from sagging.

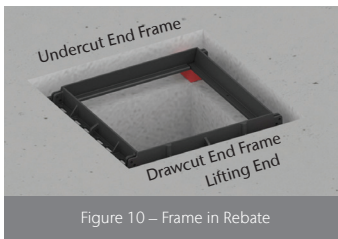

Figure 10 – Frame in Rebate

Step 4. Set up internal formwork.

Set up the internal formwork to ensure that the frame will be fully supported after the concrete pour.

The internal formwork must be set up not to obstruct the cover sitting in the frame.

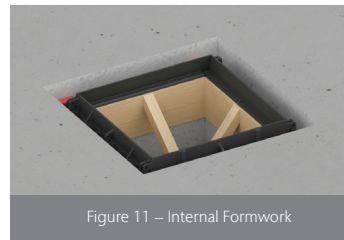

Figure 11 – Internal Formwork

NOTE:

For Class D to Class G installations, reinforcing may be required in the rebate under the frame. The reinforcement should be installed to the engineer's details.

Step 5. Put the cover in the frame.

To ensure correct seating of the covers, it is important to thoroughly clean the seat areas of the covers and frame. These surfaces must be free from dirt and debris.

Reassemble by aligning the marks (**Step 2**) on the frame and covers and ensuring they are level at the top.

Check for any diagonal rocking and adjust the packing as needed. If the covers are not level, the covers and frame seats may not be obstruction-free and/or the frame is damaged due to rough handling. It is critical that the covers are properly seated in the frame and are not obstructed by any internal formwork.

Replace all the locking bolts and caps in the covers.

For Class D and Class G infill covers, block out the holes in the cover with metal sheeting.

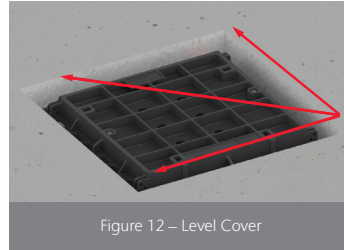

Figure 12 – Level Cover

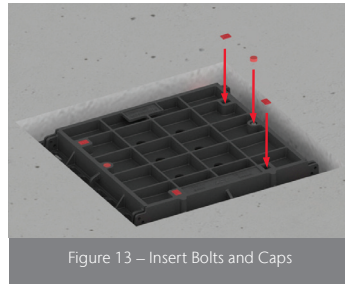

Figure 13 – Insert Bolts and Caps

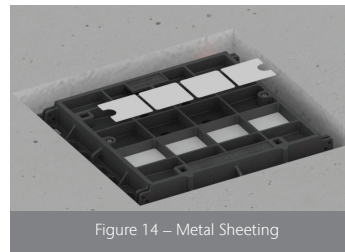

Figure 14 – Metal Sheeting

Step 6. Pour the concrete.

Ensure the frames are fully supported.

Simultaneously fill the rebate gap, and infill covers with concrete as specified in Table 2.

Minimum Requirements

32 MPa compressive strength
400 kg/m³ cement content
12mm aggregate size

Table 2 – Concrete Specification

Ensure all cavities and pockets are filled with concrete by tapping the covers and frame to compact the concrete well.

Screed off the excess concrete and finish the surface as required. The edges of the cover and frame should be visible.

To avoid damage to the concrete and frame, wait for **at least 24 hours** before removing the covers. Early removal may cause twisting of the frame and damage to the supporting concrete making it difficult to remove or put the covers back in the frame.

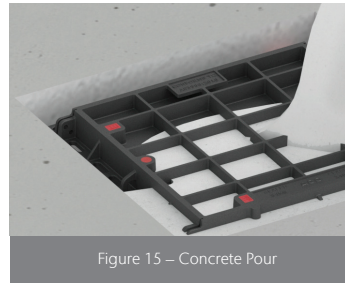

Figure 15 – Concrete Pour

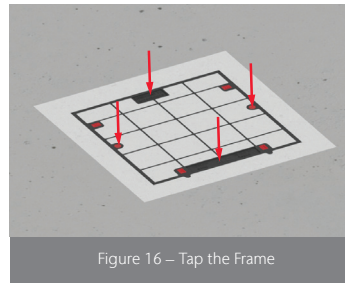

Figure 16 – Tap the Frame

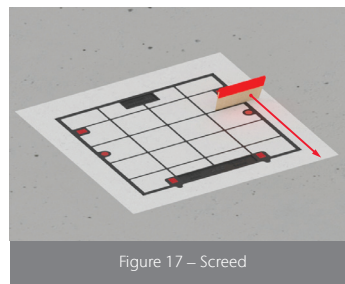

Figure 17 – Screed

Step 7. Seal the unit.

After the concrete has cured, remove the covers, and strip the internal formwork.

Clean the seat area of the covers and frame. It is important that these surfaces are dirt and debris free.

Liberaly apply Sealing Grease (Part No. 73131) to the vertical and horizontal seating area of the covers and frame to assist in maintenance. It is advised to have a build-up of at least 3mm.

Using the marks on the frame and covers, place the covers back into the frame.

Use a rubber mallet to tap the keyholes until the covers are flush.

Replace all the locking bolts and caps in the covers.

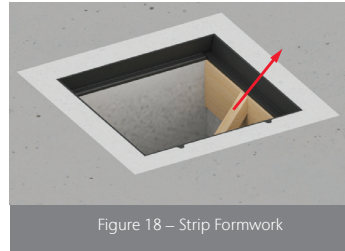

Figure 18 – Strip Formwork

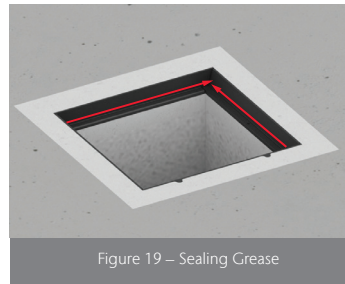

Figure 19 – Sealing Grease

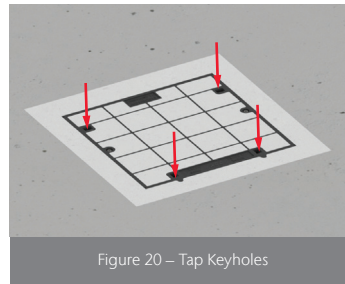

Figure 20 – Tap Keyholes

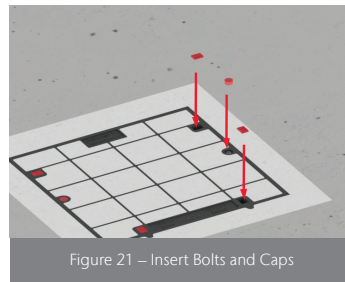

Figure 21 – Insert Bolts and Caps

4

Installation Procedure For Multipart Cover Systems

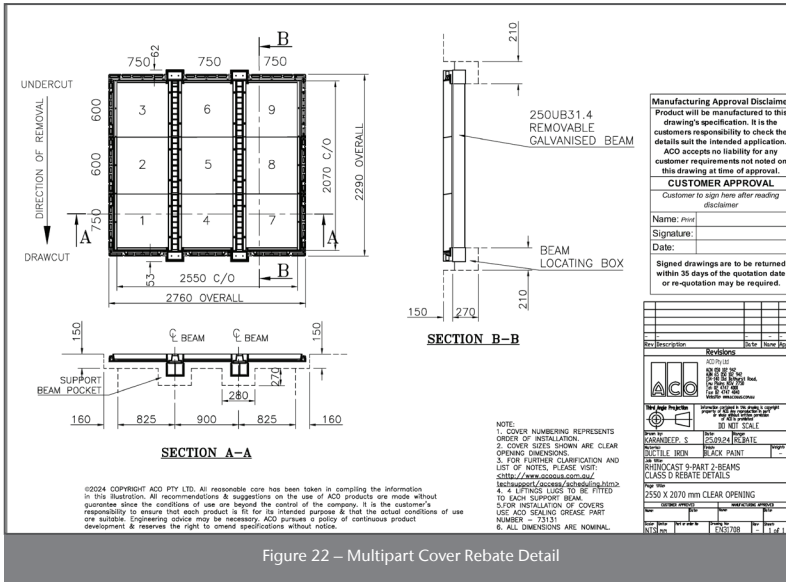

Figure 22 – Multipart Cover Rebate Detail

Step 1. Form the pit and rebate.

To form up the access pit and rebate, use the Multipart Cover Rebate Detail provided by ACO (an example is shown in Figure 22). Make sure the pit clear opening, beam pockets, and pit wall rebates are consistent with the details provided.



Figure 23 – Rebate

The covers are numbered on the drawing to indicate their position and installation order. The frames and beams are also numbered for easy identification, refer to Figure 24.

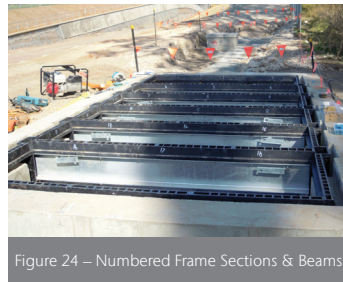

Figure 24 – Numbered Frame Sections & Beams

The frame is delivered in sections. Make sure the end frame components with beam locating boxes mate with side frame components.

Step 2. Position frames in rebate.

Set the end frames so that the beam locating boxes are positioned with the corresponding beam pocket/s in the slab. Ensure all the undercut frames are installed at the opposite end of the lifting end (drawcut).

Pack under the corner of the multipart frame to raise and level the frame to the finished floor level.

Leave a clearance of at least 50mm between the concrete beam pocket/s and the beam locating boxes. This portion experiences high stress concentrations, necessitating a substantial amount of concrete to distribute the load.

Place the side frames into position and bolt (finger tight) to the end frames.

It is recommended to use surveying equipment to ensure that the frames are level and square. Check carefully for any discrepancies along the frames and diagonals.

Ensure the frames and packing pieces do not protrude into the clear opening of the pit.

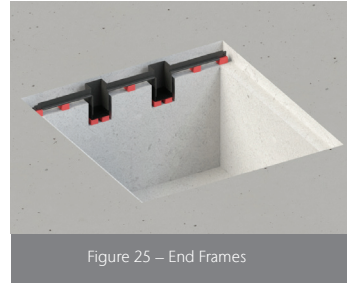

Figure 25 – End Frames

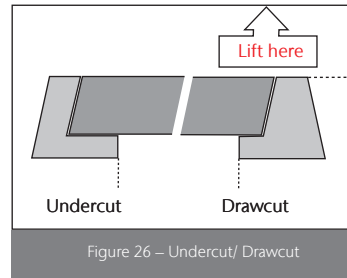

Figure 26 – Undercut/ Drawcut

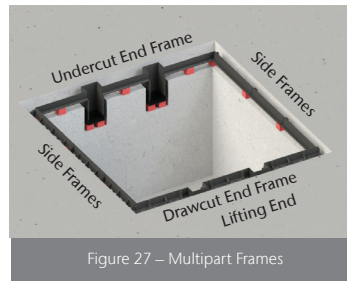

Figure 27 – Multipart Frames

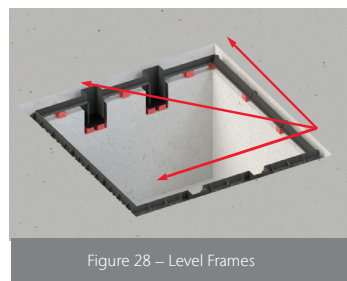

Figure 28 – Level Frames

Step 3. Install beam/s.

Using machinery, lower the beams into the corresponding boxes with the lifting eyes attached to the beam.

Lifting eyes are rated with a Working Load Limit (WLL). WLL can be found on the lifting eye.



Figure 29 – Install Beams

Step 4. Set up internal framework.

Set up the internal formwork to ensure that the frame will be fully supported after the concrete pour.

The internal formwork must be set up not to obstruct the cover sitting in the frame.

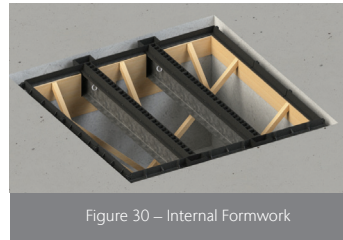

Figure 30 – Internal Formwork

NOTE:

For Class D to Class G installations, reinforcing may be required in the rebate under the frame. The reinforcement should be installed to the engineer's details.

Step 5. Put the covers in the frame.

To ensure correct seating of the covers, it is important to thoroughly clean the seat areas of the covers and frame. These surfaces must be free from dirt and debris.

Arrange the covers in the frame according to the numbered system as stated in **Step 1**.

Ensure the top edges of the covers and frame are level with each other and over the entire perimeter of the multi-part system.

Check for any diagonal rocking and adjust the packing as needed. If the covers are not level, the covers and frame seats may not be obstruction-free and/or the frame is damaged due to rough handling. It is critical that the covers are properly seated in the frame.

For Class D and Class G infill covers, block out the holes in the cover with metal sheeting.

Tighten all the (finger tight) bolts along the side frame. Replace all the caps in the covers.

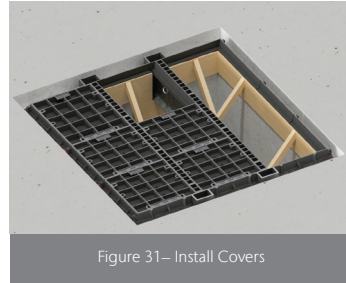

Figure 31 – Install Covers

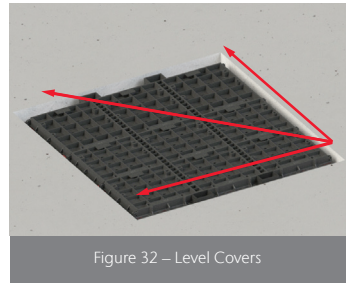

Figure 32 – Level Covers

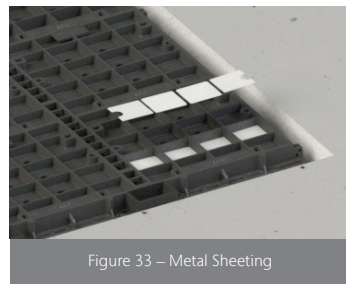

Figure 33 – Metal Sheeting

Step 6. Pour the concrete.

Ensure all the frames are fully supported.

Simultaneously fill the rebate gap, and infill covers with concrete as specified in Table 3.

Minimum Requirements
32 MPa compressive strength
400 kg/m ³ cement content
12mm aggregate size
Table 3 – Concrete Specification

Ensure all cavities and pockets are filled with concrete by tapping the covers and frame to compact the concrete well.

Screed off the excess concrete and finish the surface as required. The edges of the cover and frame should be visible.

To avoid damage to the concrete and frame, wait for at least 24 hours before removing the covers. Early removal may cause twisting of the frame and damage to the supporting concrete making it difficult to remove or put the covers back in the frame.

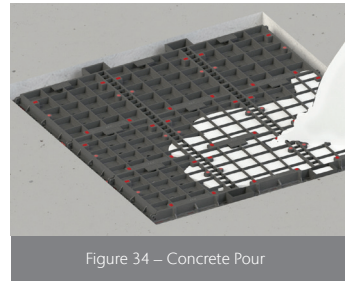

Figure 34 – Concrete Pour

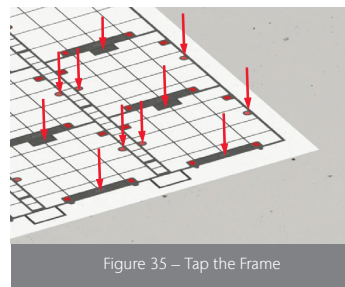

Figure 35 – Tap the Frame

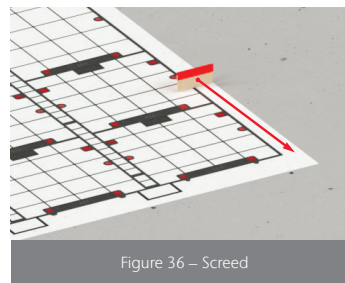

Figure 36 – Screed

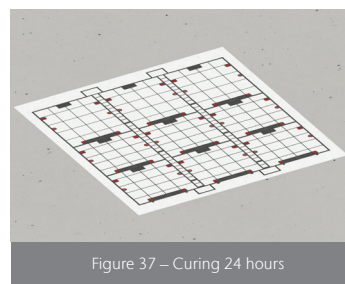

Figure 37 – Curing 24 hours

Step 7. Seal the unit.

After the concrete has cured, remove the covers, and strip the internal formwork.

Clean the seat area of the covers and frame. It is important that these surfaces are dirt and debris free.

Liberal apply Sealing Grease (Part No. 73131) to the vertical and horizontal seating area of the covers and frame to assist in maintenance. It is advised to have a build-up of at least 3mm.

Using the marks on the frame and covers, place the covers back into the frame.

Use a rubber mallet to tap the keyholes until the covers are flush.

Replace all the caps in the covers.

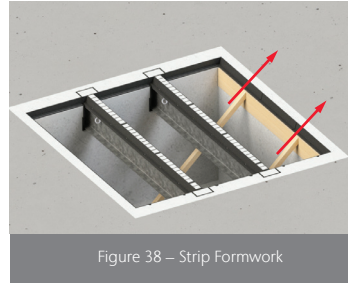

Figure 38 – Strip Formwork

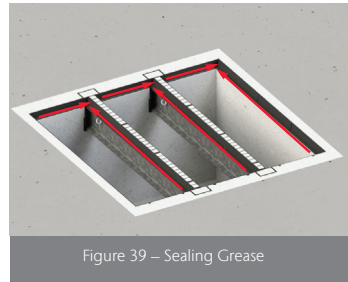

Figure 39 – Sealing Grease

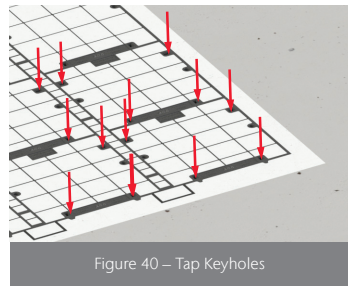

Figure 40 – Tap Keyholes

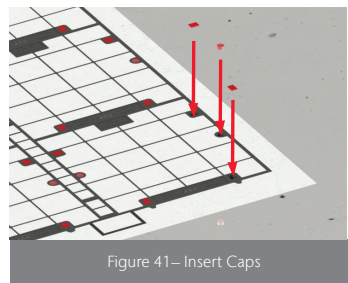

Figure 41 – Insert Caps

5

Maintenance and Access Procedure**GENERAL REQUIREMENTS**

Proper installation is crucial to prevent unwanted movement, damage, and failure when covers are under load.

Additionally, this guarantees that the design life of the product is achieved. Before removing the access cover, assess whether it is safe to do so. Make sure to clear the surrounding area of any obstacles and close it off to pedestrian and vehicular traffic when necessary.

It is important to take precautions to prevent accidental falls into the open pit below when the cover is removed. When opening or removing access covers, it is also critical to use the correct manual handling techniques and tools to minimise the risk of injuries.

TOOLS REQUIRED:

- Lifting keys
- Shifting spanner
- 2 lengths of water pipe approximately 25mm diameter (150mm longer than the width of the cover)
- Screwdriver
- Paint scraper
- Wire brush

Rhinocast® Lifting Keys & Caps

Short Handle (pair)	84654
Long Handle (pair)	84854
Sealing Grease (4L)	73131
Rectangular caps (long)	84622
Rectangular caps (short)	84620
Round caps	84626

Oxidation of Iron Over Time

Ductile iron covers and frames have a black sealer applied to protect the product for a short period after manufacture. It is not intended to be either a long term or architectural finish.

Oxidation on the surface of ductile iron products is a natural process that does not affect the structural integrity of the product and produces a rustic look.

For solid top covers, if a black finish is required, it would be recommended to paint the covers with a black rust inhibitor from time to time.

ACO Product Design Life

If properly maintained, ACO products installed in the correct application and according to ACO's installation instructions, will hold their integrity for as long as the adjacent pavement will.

For example, if the pavement is designed for 50 years and is not damaged during this time, the ACO product will last for 50 years.

Unforeseen and adverse conditions out of ACO's control may affect the life of the product.

RHINOCAST® COVER REMOVAL

1. Remove caps and locking bolts from covers. Ensure keyholes are free from dirt and debris. Use one of the Rhinocast lifting keys, choosing the appropriate one. See **Figures 42 and 43** for the options.

2. Insert the key into the keyhole and turn it a quarter turn clockwise and lock in position with the nut. Position the jacking bolt over the frame and screw down with a shifting spanner to break the seal.

For added protection against damage to tile, paver or concrete infill, use at least 100 x 100 x 3mm thick steel plate under the jacking bolt for decorative edge covers.

3. Once seal is broken, using standard, long handled lifting keys, lift the cover by leaning forward on the handles. Insert two sections of pipe to enable the cover to be rolled clear of the opening.

4. For multipart covers, remove the covers in numerical order and stack at the end of the row to ensure they are reinstalled in the same position. See **Figure 44**.

5. Examine the covers and frame thoroughly to check for any signs of damage or fatigue cracks.

NOTE:

If you have trouble breaking the seal, apply penetrating oil and wait for 24 hours. Tap joint gently with a bolt to avoid damaging the pavement and try using the jacking bolt again. Take necessary measures to protect decorative edge and pavement finish if needed.



Figure 42 – Short Handle Lifter (pair) Part No. 84654



Figure 43 – Long Handle Lifter (pair) Part No. 84854

RHINOCAST® COVER REPLACEMENT

1. Before reinstating the cover, make sure to clean both the cover and frame seating surfaces to remove any dirt, rust or debris. It is recommended to use wire brush or scraper.
2. Liberally apply **Sealing Grease (Part No. 73131)** to the vertical and horizontal seating area of the covers and frame. It is advised to have a build-up of at least 3mm.
3. Using long handled lifting keys and pipe sections, roll cover back into position and gently lower onto frame seat.
4. Lift and lower cover again to evenly distribute sealing grease.
5. For multiparts, replace in reverse order to ensure each cover is returned to its correct position. See **Figure 44**.
6. Replace caps and bolts as required.

Note about weatherproofing

AS 3996 requires compliance in a number of areas including gas and water tightness. Due to the number of removable components including beams and individual covers, multipart access covers by their very design cannot be made water tight. This is why AS 3996 excludes large access cover systems from its scope. ACO multipart covers are suitable for applications requiring general weather resistance on well drained enclosures. A reasonable degree of weather resistance can be achieved by sealing the edges of covers, frame interfaces and lifting holes each time the cover is removed for servicing.

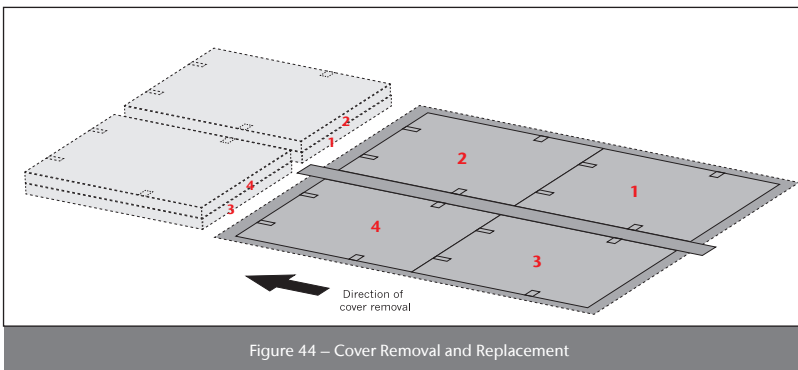

Figure 44 – Cover Removal and Replacement

ACO Pty Ltd

ABN 65 050 102 942

www.acoaus.com.au

New South Wales and Head Office

134-140 Old Bathurst Road
Emu Plains NSW 2750
Australia
Telephone +61 2 4747 4000

Queensland

467 Tufnell Road
Banyo QLD 4014
Telephone (07) 3292 4500
acoqld@acoaus.com.au

Western Australia

33-35 Sorbonne Crescent
Canning Vale WA 6155
Telephone (08) 6250 3700
acowa@acoaus.com.au

Sales Hotlines

Telephone 1300 765 226
sales@acoaus.com.au

Technical Services

technical@acoaus.com.au

Victoria

9 Overseas Drive
Noble Park VIC 3174
Telephone (03) 9790 8800
acovic@acoaus.com.au

South Australia

Unit 14, 17-19 Churchill Road North
Dry Creek SA 5094
Telephone (08) 8162 7800
acosant@acoaus.com.au

© December 2024 ACO Pty Ltd.

All reasonable care has been taken in compiling the information in this document. All recommendations and suggestions on the use of ACO products are made without guarantee since the conditions of use are beyond the control of the company. It is the customer's responsibility to ensure that each product is fit for its intended purpose and that the actual conditions are suitable. ACO Pty Ltd pursues a policy of continuous product development and reserves the right to amend specifications without notice.

#IN0007

ACO. we care for water

